

Attachment A – Application Form

Please complete, providing as much detail as possible, and return to:

ACTPGFlagsandBanners@act.gov.au or

ACT Property Group, Response Centre,

Attention: Flags Officer

Chief Minister, Treasury and Economic Development Directorate

PO Box 777 Fyshwick ACT 2609

APPLICANT DETAILS

Name of Organisation [Click here to enter text.](#)

Address [Click here to enter text.](#)

Postcode [Click here to enter text.](#)

Contact Person [Click here to enter text.](#)

Phone [Click here to enter text.](#)

Mobile [Click here to enter text.](#)

Fax Number [Click here to enter text.](#)

E-mail Address [Click here to enter text.](#)

Description of the Event [Click here to enter text.](#)

Event Start Date [Click here to enter text.](#)

Event Finish Date [Click here to enter text.](#)

Proposed Dates for Installation: [Click here to enter text.](#)

Removal: [Click here to enter text.](#)

Additional comments on the event [Click here to enter text.](#)

IMPORTANT

- You must provide a full colour design of proposed flags or banners with this application.
- Applicants should not manufacture flags and banners before the Territory has provided the applicant with final confirmation that their booking is successful.
- The ACT Government will not fly flags or banners that are made of vinyl or vinyl-like materials even if an application has been approved. In such a situation, the ACT Government will not be liable for any production costs of any vinyl flags/banners that applicants have incurred.
- Further, in the situation that the Territory has flown flags and banners made from vinyl or vinyl like material in the past, the Territory will not accept or allow these flags or banners to be flown from ACT Government owned sites.
- For an application to be confirmed the full amount of the booking must be paid. Until then the booking cannot be confirmed and other paid bookings will take precedence.

LOCATIONS REQUESTED

An applicant must select all flags or banners located at one site – an applicant cannot select a smaller number of flags and banners at any site.

The number and availability of sites for hire listed below is correct at the time of publication. However, please note that from time to time the number of sites available may vary. ACT Property Group will endeavour to notify an applicant of any changes to the availability of sites as soon as possible. The ACT Government will not be liable for any production costs of additional flags/banners that applicants have incurred as a result of the reduction in site numbers available to the applicant.

Pole Group No.	Location:	Flag/ Banner/ Double Site:	Pole Count	No. Flags	Number of Banners	Req'd <input type="checkbox"/>
Area: Lake Burley Griffin						
1	Vernon Circle	Flag pole	8	8		<input type="checkbox"/>
2*	Commonwealth Avenue - North	Flag pole	16	16		<input type="checkbox"/>
3*	Commonwealth Avenue - South	Flag pole	16	16		<input type="checkbox"/>
4*	Kings Avenue Bridge - South	Flag pole	16	16		<input type="checkbox"/>
5*	Kings Avenue Bridge - North	Flag pole	16	16		<input type="checkbox"/>
6*	Kings Avenue Overpass	Flag pole	16	16		<input type="checkbox"/>
7	Commonwealth Ave (both sides)	Banner	26		26	<input type="checkbox"/>
8	Kings Ave (both sides)	Banner	52		52	<input type="checkbox"/>
* Final approval by the National Capital Authority will be required for applications relating to flagpoles under the responsibility of the Commonwealth (marked with an asterisk above)						
Area: City CBD						
9	Allara Street - Foot Bridge	Flag pole	2	2		<input type="checkbox"/>
10	Mort Street	Banner	2		2	<input type="checkbox"/>
11	Alinga Street	Banner	3		3	<input type="checkbox"/>
12	Nangari Street	Flag pole	3	3		<input type="checkbox"/>
13	City Walk - Petrie Plaza	Flag pole	4	4		<input type="checkbox"/>
14	City Walk - Canberra Centre	Flag pole	4	4		<input type="checkbox"/>
15	Garema Place	Flag pole	5	5		<input type="checkbox"/>
16	Akuna Street	Banner	5		5	<input type="checkbox"/>
17	Civic Square Community Banner Poles (These poles require 5	Double Banner Poles	5		10	<input type="checkbox"/>

Pole Group No.	Location:	Flag/ Banner/ Double Site:	Pole Count	No. Flags	Number of Banners	Req'd <input type="checkbox"/>
left-sided and 5 right-sided banners)						
18	Binara Street	Banner	6		6	<input type="checkbox"/>
19	Vernon Circle City Hill	Double Banner Poles	6		12	<input type="checkbox"/>
20	Bunda Street	Banner	14		14	<input type="checkbox"/>
21	London Circuit	Banner	60		60	<input type="checkbox"/>
22	Vernon Circle City Hill (These poles require 9 reversed or left-sided banners)	Banner	9		9	<input type="checkbox"/>
Area: North Canberra						
23	Gundaroo Drive	Banner	4		4	<input type="checkbox"/>
24	Barton Highway – William Slim Drive	Banner	10		10	<input type="checkbox"/>
25	Morshead Drive	Banner	34		34	<input type="checkbox"/>
26	Parkes Way	Banner	68		68	<input type="checkbox"/>
Area: Belconnen						
27	Mouat St	Banner	5		5	<input type="checkbox"/>
28	Leverrier Cres	Banner	12		12	<input type="checkbox"/>
29	Battye St	Banner	32		32	<input type="checkbox"/>
30	Ginninderra Drive	Banner	47		47	<input type="checkbox"/>
31	Benjamin Way	Banner	50		50	<input type="checkbox"/>
32	Haydon Drive	Banner	60		60	<input type="checkbox"/>
Area: Gungahlin						
33	Gold Creek Village - O'Hanlon Place	Flag pole	12	12		<input type="checkbox"/>
Area: Inner City						
34	Area 1 - Gould Street	Banner	1		1	<input type="checkbox"/>
35	Area 1 - Masson Street	Banner	1		1	<input type="checkbox"/>
36	Area 1 - Watson Street	Banner	1		1	<input type="checkbox"/>
37	Area 1 - Lonsdale Street	Banner	8		8	<input type="checkbox"/>
38	Area 1 - Girrahween Street	Banner	8		8	<input type="checkbox"/>
39	Area 1 - Elouera Street	Banner	12		12	<input type="checkbox"/>

Pole Group No.	Location:	Flag/ Banner/ Double Site:	Pole Count	No. Flags	Number of Banners	Req'd <input type="checkbox"/>
40	Area 1 - Mort Street	Banner	12		12	<input type="checkbox"/>
41	Area 2 - Akuna Street	Banner	1		1	<input type="checkbox"/>
42	Area 2 - Binara Street	Banner	1		1	<input type="checkbox"/>
43	Area 2 - Nangari Street	Banner	3		3	<input type="checkbox"/>
44	Area 2 - Bunda Street	Banner	4		4	<input type="checkbox"/>
45	Area 2 - Ballumbir Street	Banner	13		13	<input type="checkbox"/>
46	Area 3 - Constitution Ave	Banner	4		4	<input type="checkbox"/>
47	Area 3 - Allara Street	Banner	4		4	<input type="checkbox"/>
48	Area 3 - London Cct	Banner	6		6	<input type="checkbox"/>
49	Area 3 - Coranderrk Street	Double Banner Poles	8		8	<input type="checkbox"/>
50	Area 4 - Gordon Street	Banner	2		2	<input type="checkbox"/>
51	Area 4 - Edinburgh Ave	Banner	8		8	<input type="checkbox"/>
52	Area 4 - London Cct	Banner	11		11	<input type="checkbox"/>
53	Area 4 - Marcus Clarke Street	Banner	14		14	<input type="checkbox"/>
54	Area 5 - Alinga Street	Banner	4		4	<input type="checkbox"/>
55	Area 5 - London Cct	Banner	12		12	<input type="checkbox"/>
56	Area 6 - London Cct	Banner	12		12	<input type="checkbox"/>
57	Area 6 - Marcus Clarke Street	Banner	16		16	<input type="checkbox"/>
58	Area 7 - Moore Street	Banner	1		1	<input type="checkbox"/>
59	Area 7 - Bunda Street	Banner	2		2	<input type="checkbox"/>
60	Area 7 - Mort Street	Banner	3		3	<input type="checkbox"/>
61	Area 7 - Rudd Street	Banner	7		7	<input type="checkbox"/>
62	Area 7 - Marcus Clarke Street	Banner	8		8	<input type="checkbox"/>
63	Area 7 - Cooyong Street	Banner	13		13	<input type="checkbox"/>
64	Area 7 - Barry Drive	Banner	14		14	<input type="checkbox"/>
65	Multipoles – Bunda Street	Banner	7		7	<input type="checkbox"/>
66	Multipoles – Scotts Crossing	Banner	13		13	<input type="checkbox"/>
67	Multipoles – George Street	Banner	20		20	<input type="checkbox"/>
Total pole count				122 Flags	882 Banners	

COST OF HIRING FLAGS AND/OR BANNER POLES

Costs are determined and charged on a cost-recovery basis and include GST.

Flags

Processing Fee	\$184.50 per application
Cost for the Installation/Removal of each flag within business hours	\$30.75 per flag
Cost for the Installation/Removal of each flag after hours	\$51.25 per flag
Minimum charge for the installation and removal of flags within business hours	\$461.25
Minimum charge for the installation and removal of flags after hours	\$820.00
Daily hire cost for first 28 days for flagpoles	No Charge
Daily hire cost for each flag after the initial 4 week booking	\$2.05 per flag/ banner/day

Banners

Processing Fee	\$184.50 per application
Cost for the Installation/Removal of each banner in business Hours	\$82.00 per banner
Cost for the Installation/Removal of each banner after hours	\$112.75 per banner
Minimum charge for the installation and removal of banners in business hours	\$1025.00
Minimum charge for the installation and removal of banners after hours	\$2050.00
Daily hire cost for first 28 days for bannerpoles	No Charge
Daily hire cost for each banner pole after the initial 4 week booking	\$2.05 per flag/ banner/day
Hire of cherry picker, traffic management plans, implementation of traffic management.	POA + 12%

NOTES

- Locations and dates are subject to availability and all requests will be considered temporary bookings until confirmation is given to the applicant.
- Applications will be processed in the order in which they are received.
- The ACT Government reserves the right to remove flags and banners for events such as visiting dignitaries, Territory or Federal Government events, and/or any other events. All efforts will be made to notify any affected party as soon as possible. The ACT Government will not provide any financial compensation in any event.
- ACT Government events will take precedence in the situation where there are multiple applications for flying banners in a certain location at the same/similar times.
- ACT Government will not be held liable for any loss or damage that may occur to flags and banners.
- Final approval by the National Capital Authority will be required for applications relating to flagpoles under the responsibility of the Commonwealth (marked with an asterisk above);

** NCA approval is required for the first time the flag is used from 1 October 2009 and that approval becomes a standing approval for future use, unless otherwise advised by the NCA. ACT Property Group will keep a register of NCA Standing Approvals for Flags.*

By signing this application, I acknowledge that I have read and understand the ACT Government Flags and Banners Operational Guidelines.

Applicant's Signature: _____ Date: _____

Attachment B – List of Main Avenues and Approach Routes to Canberra

Main Avenues

- State Circle
- Commonwealth Avenue
- Brisbane Avenue
- Canberra Avenue (to Hume Circle)
- Adelaide Avenue
- Northbourne Avenue
- University Avenue
- Limestone Avenue (south of Ainslie)
- Kings Avenue
- Sydney Avenue
- Hobart Avenue
- Melbourne Avenue
- Perth Avenue
- Edinburgh Avenue
- Ainslie Avenue
- Anzac Parade

Approach Routes

- Barton Highway
- Federal highway
- Fairbairn Avenue
- Morshead Drive/Pialligo Avenue to the ACT border
- Canberra Avenue from Hume Circle to the ACT border
- Monaro Highway and its extension as the Eastern Parkway to Morshead Drive.

Attachment C – Flag and Banners specifications

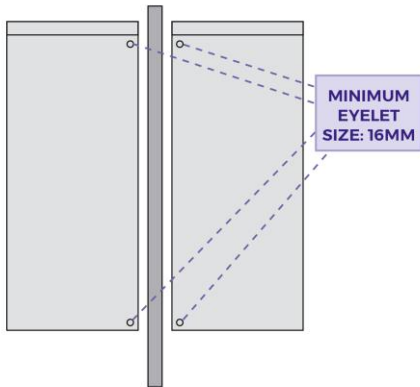

Standard Double Banner (left-hand, right-hand or double)

850mm x 2000 mm
90mm pocket
2 x minimum 16mm eyelet holes

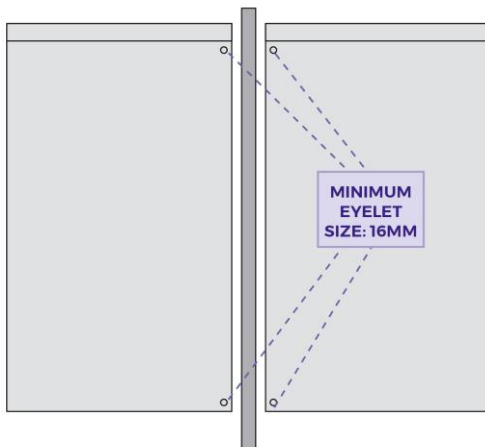

Civic Square Banners (double)

1450mm x 2000-2500mm
90mm pocket
2 x minimum 16mm eyelet holes



Flag

Up to 1500mm x 1000-2500mm
2 x plastic toggle or sister clip to secure flag
to the top of the flagpole